



Cambridge International Examinations
Cambridge International General Certificate of Secondary Education

CANDIDATE
NAME

CENTRE
NUMBER

--	--	--	--	--

CANDIDATE
NUMBER

--	--	--	--

MATHEMATICS

0580/31

Paper 3 (Core)

October/November 2014

2 hours

Candidates answer on the Question Paper.

Additional Materials:

Electronic calculator

Geometrical instruments

Tracing paper (optional)

READ THESE INSTRUCTIONS FIRST

Write your Centre number, candidate number and name on all the work you hand in.

Write in dark blue or black pen.

You may use an HB pencil for any diagrams or graphs.

Do not use staples, paper clips, glue or correction fluid.

DO NOT WRITE IN ANY BARCODES.

Answer **all** questions.

If working is needed for any question it must be shown below that question.

Electronic calculators should be used.

If the degree of accuracy is not specified in the question, and if the answer is not exact, give the answer to three significant figures. Give answers in degrees to one decimal place.

For π , use either your calculator value or 3.142.

At the end of the examination, fasten all your work securely together.

The number of marks is given in brackets [] at the end of each question or part question.

The total of the marks for this paper is 104.

The syllabus is approved for use in England, Wales and Northern Ireland as a Cambridge International Level 1/Level 2 Certificate.

This document consists of **16** printed pages.



1 A carton of fruit juice contains apple, orange, pineapple and tropical juices.

(a) They are mixed in the ratio

$$\text{apple : orange : pineapple : tropical} = 9 : 7 : 4 : 5.$$

The carton contains 540 millilitres of apple juice.

(i) Show that the total amount of fruit juice in the carton is 1.5 **litres**.

Answer(a)(i)

[3]

(ii) Calculate the amount of tropical juice in the carton.
Give your answer in millilitres.

Answer(a)(ii) ml [2]

(iii) 70% of the tropical juice is mango.

Calculate the amount of mango juice in the carton.

Answer(a)(iii) ml [2]

(b) A shopkeeper pays \$36 for 16 cartons.

(i) How much does he pay for one carton?

Answer(b)(i) \$..... [1]

(ii) He sells $\frac{7}{8}$ of the 16 cartons for \$3.40 each and the rest for \$2.50 each.

Calculate the total amount he receives from selling the cartons.

Answer(b)(ii) \$..... [2]

(iii) Calculate his percentage profit.

Answer(b)(iii)% [3]

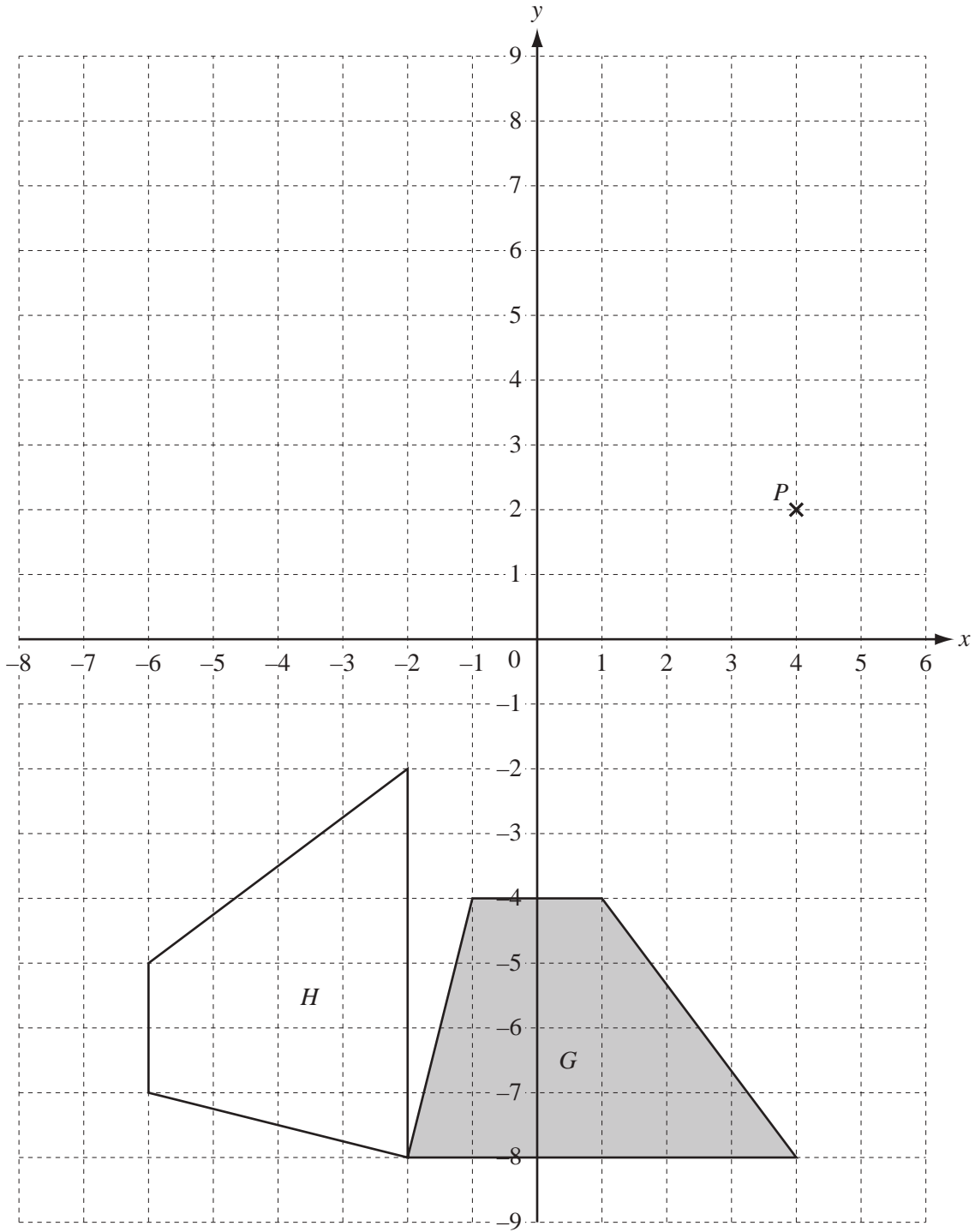

Two congruent quadrilaterals, G and H , and a point P are shown on this 1 cm^2 grid.

(a) (i) Write down the mathematical name of the shaded quadrilateral.

Answer(a)(i) [1]

- (ii) Calculate the area of the shaded quadrilateral.
Give the units of your answer.

Answer(a)(ii) [3]

- (b) Describe fully the **single** transformation that maps quadrilateral G onto quadrilateral H .

Answer(b)
..... [3]

- (c) On the grid, draw the images of quadrilateral G after the following transformations.

(i) Reflection in the line $y = 0$. [2]

(ii) Translation by the vector $\begin{pmatrix} -5 \\ 7 \end{pmatrix}$. [2]

(iii) Enlargement by scale factor 0.5 with centre P . [2]

- (d) On quadrilateral H mark, with an arc, an obtuse angle. [1]
-

- 3 12 athletes took part in the 100 metres race.
 11 of these athletes also took part in the long jump.
 The times and distances, each measured correct to 3 significant figures, for these athletes are shown in the table.

Athlete	A	B	C	D	E	F	G	H	I	J	K	L
100 m time (seconds)	12.1	10.3	12.8	10.7	12.6	11.2	12.0	12.4	10.6	12.7	11.8	11.1
Long jump (metres)	×	7.60	5.15	7.25	6.72	6.30	5.60	6.20	6.90	5.70	6.85	6.70

(a) The scatter diagram shows the times and distances for athletes B to H.

(i) Plot the times and distances for athletes I, J, K and L.

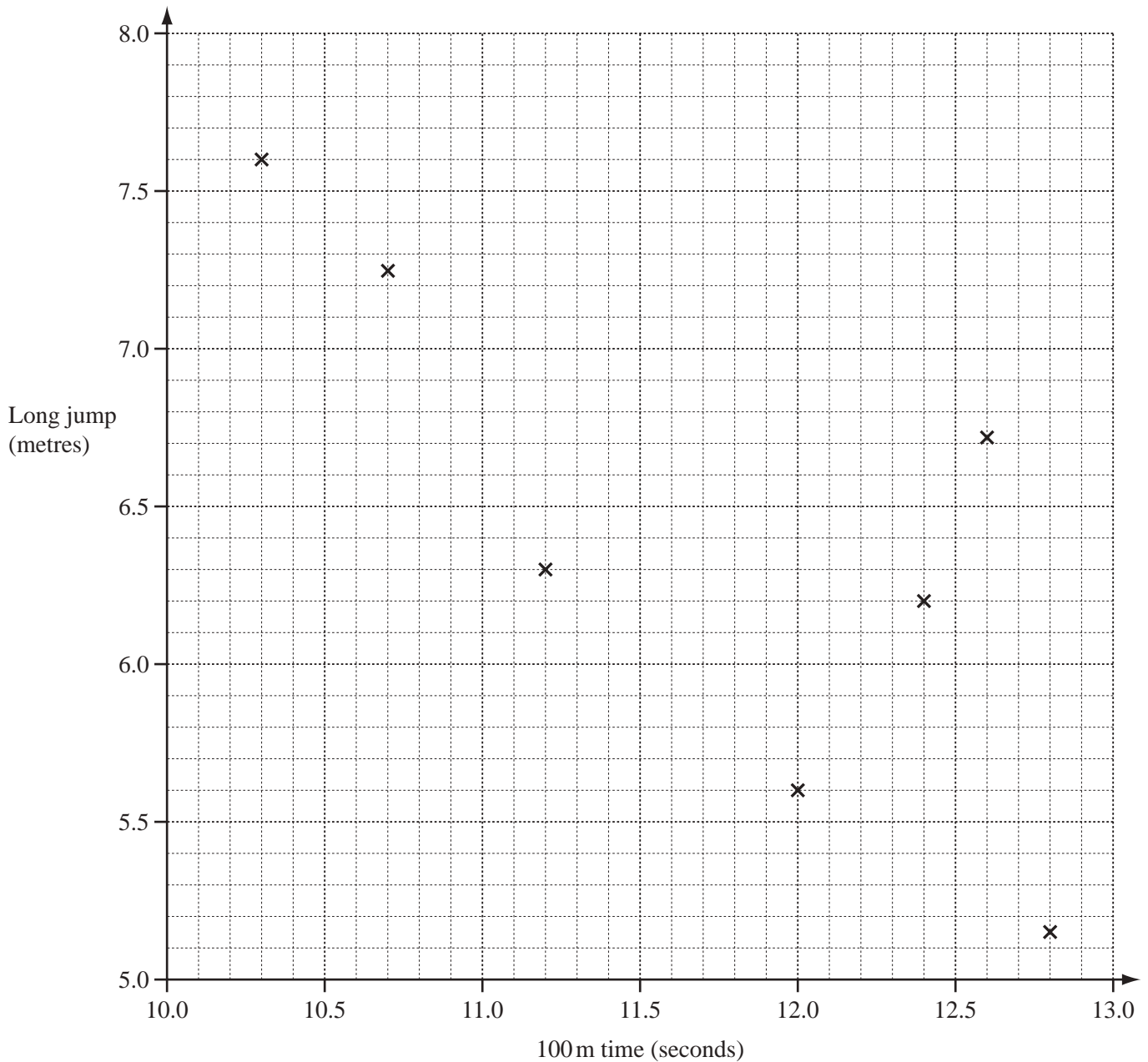

[2]

(ii) On the scatter diagram, draw a line of best fit. [1]

(iii) Athlete A did not take part in the long jump.

Use your line of best fit to estimate a long jump distance for athlete A.

Answer(a)(iii) m [1]

(iv) What type of correlation is shown on the scatter diagram?

Answer(a)(iv) [1]

(v) Describe in words the relationship between the time for 100 metres and the distance in the long jump.

Answer(a)(v)

..... [1]

(b) Use the table of times and distances to work out

(i) the mean of the 100 metres times,

Answer(b)(i) s [2]

(ii) the percentage of athletes who ran 100 metres in less than 11.5 seconds,

Answer(b)(ii) % [2]

(iii) the range of the distances jumped by the 11 athletes, *B* to *L*.

Answer(b)(iii) m [1]

4

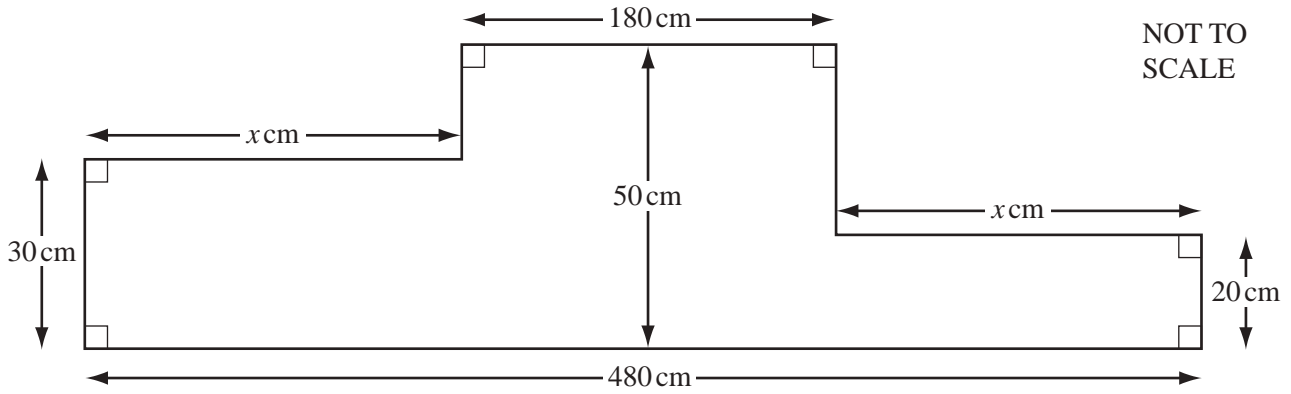

The diagram shows the cross section of a medal presentation platform.

(a) Show that $x = 150$.

Answer(a)

[2]

(b) Work out the perimeter of the cross section.

Answer(b) cm [2]

(c) (i) Calculate the area of the cross section.

Answer(c)(i) cm^2 [2]

(ii) The platform is a prism, 170 cm deep.

Find the volume of the platform.

Answer(c)(ii) cm^3 [1]

(iii) The prism is completely filled with a light material.
1 **cubic metre** of this material has mass 16 kg.

Calculate the mass of the material used.

Answer(c)(iii) kg [2]

- 5 (a) Write in figures six million three thousand and seventy six.

Answer(a) [1]

- (b) (i) Work out the value of p when $p = -0.6 \div 1.6$.

Answer(b)(i) $p =$ [1]

- (ii) Work out the value of q when $q = -0.6 - 1.6$.

Answer(b)(ii) $q =$ [1]

- (iii) Use one of the symbols $>$, $<$, \geq , \leq , $=$ to complete this statement.

p q [1]

- (c) Mount Robson in Canada has a height of 3950 metres, correct to the nearest 10 metres.

Complete the following statement about the height, h m, of Mount Robson.

Answer(c) $\leq h <$ [2]

- (d) Calculate $2\frac{1}{12} \div 1\frac{1}{4}$.

Give your answer as a decimal, correct to 4 significant figures.

Answer(d) [2]

- (e) (i) Write down the value of 8^0 .

Answer(e)(i) [1]

- (ii) Work out 5^{-3} .
Write your answer as a fraction.

Answer(e)(ii) [1]

- (iii) Simplify the expression.

$$8x^5 \times 3x^4$$

Answer(e)(iii) [2]

- 6 (a) (i) Complete the table of values for $y = 8 - x^2$.

x	-3	-2	-1	0	1	2	3
y	-1			8	7		-1

[2]

- (ii) On the grid, draw the graph of $y = 8 - x^2$ for $-3 \leq x \leq 3$.

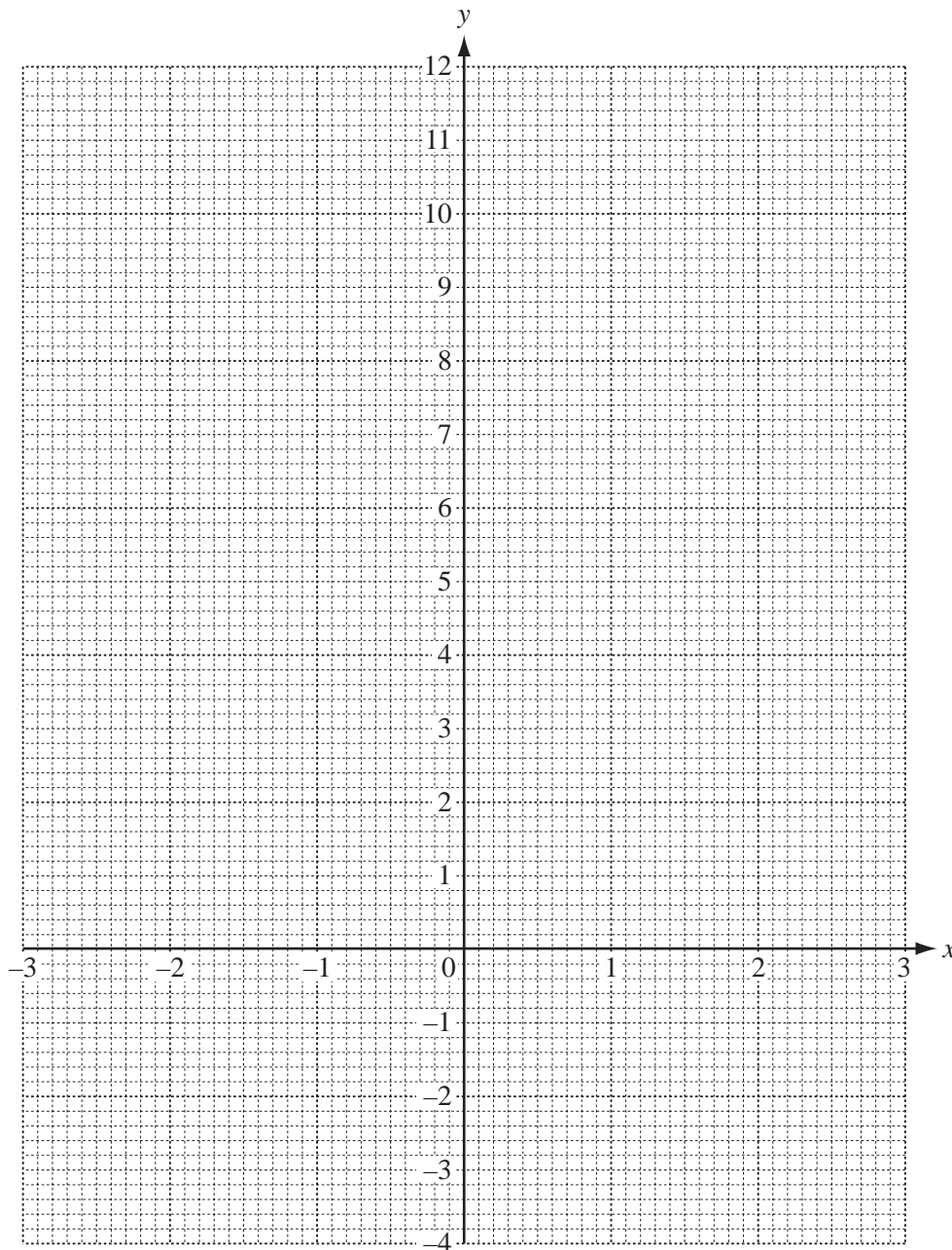

[4]

(iii) Write down the equation of the line of symmetry of the graph.

Answer(a)(iii) [1]

(iv) Use your graph to solve the equation $8 - x^2 = 0$.

Answer(a)(iv) $x =$ or $x =$ [2]

(b) (i) On the grid, plot the points $(-2, 8)$ and $(2.5, -1)$.
Draw a straight line through these points. [2]

(ii) Find the equation of your line in the form $y = mx + c$.

Answer(b)(ii) $y =$ [3]

(iii) Write down the co-ordinates of the point of intersection of your line with $y = 8 - x^2$.

Answer(b)(iii) (.....,) [1]

- 7 The scale drawing represents the positions of 3 towns, *A*, *B* and *C*.
The scale is 1 centimetre represents 4 kilometres.

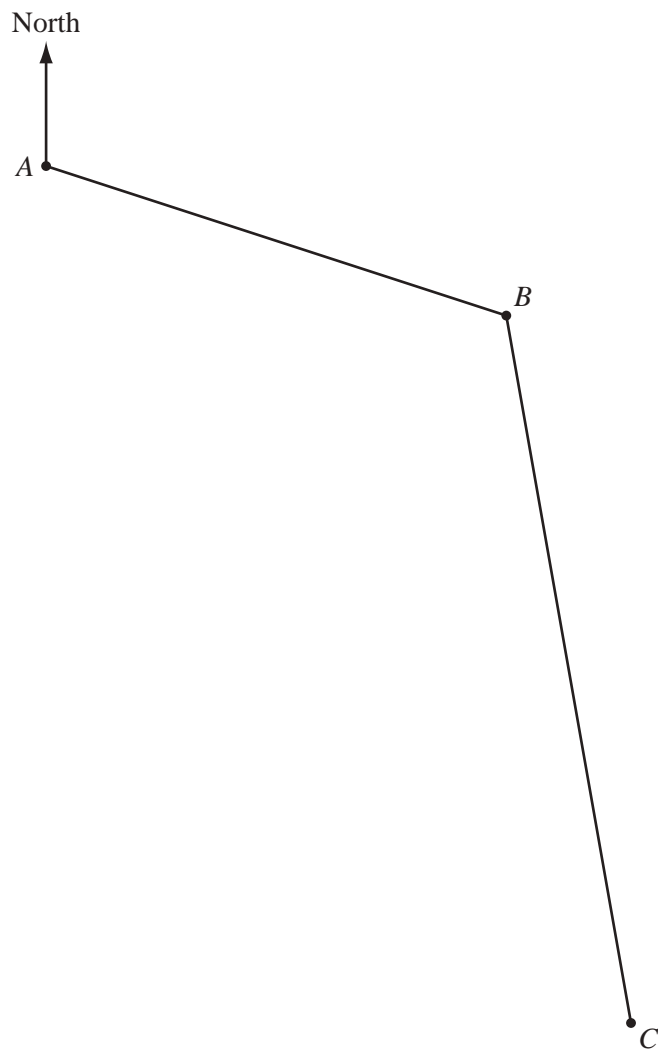

Scale: 1 cm to 4 km

(a) Measure the bearing of B from A .

Answer(a) [1]

(b) A transmitter is placed near to the 3 towns.

(i) The transmitter is equidistant from A and B .

Using a straight edge and compasses only, construct the locus of points equidistant from A and B . [2]

(ii) The transmitter is also on the bisector of angle ABC .

Using a straight edge and compasses only, construct the bisector of angle ABC . [2]

(iii) Mark the position, T , of the transmitter on the scale drawing. [1]

(c) Work out the actual distance, in kilometres, of town A from T .

Answer(c) km [2]

(d) The signal from the transmitter has a range of 30 kilometres in all directions.

On the scale drawing, construct the locus of points 30 kilometres from T . [2]

(e) Would the signal from the transmitter reach town C ?
Give a reason for your answer.

Answer(e) because [1]
.....

- 8 (a) One day a survey is taken of the ages of 120 children at a fairground.
The results are shown in the frequency table.

Age in completed years	Number of children
1 to 3	12
4 to 6	19
7 to 9	32
10 to 12	41
13 to 15	9
16 to 18	7

- (i) On the grid, draw a bar chart for this data.
Complete the scale on the frequency axis.

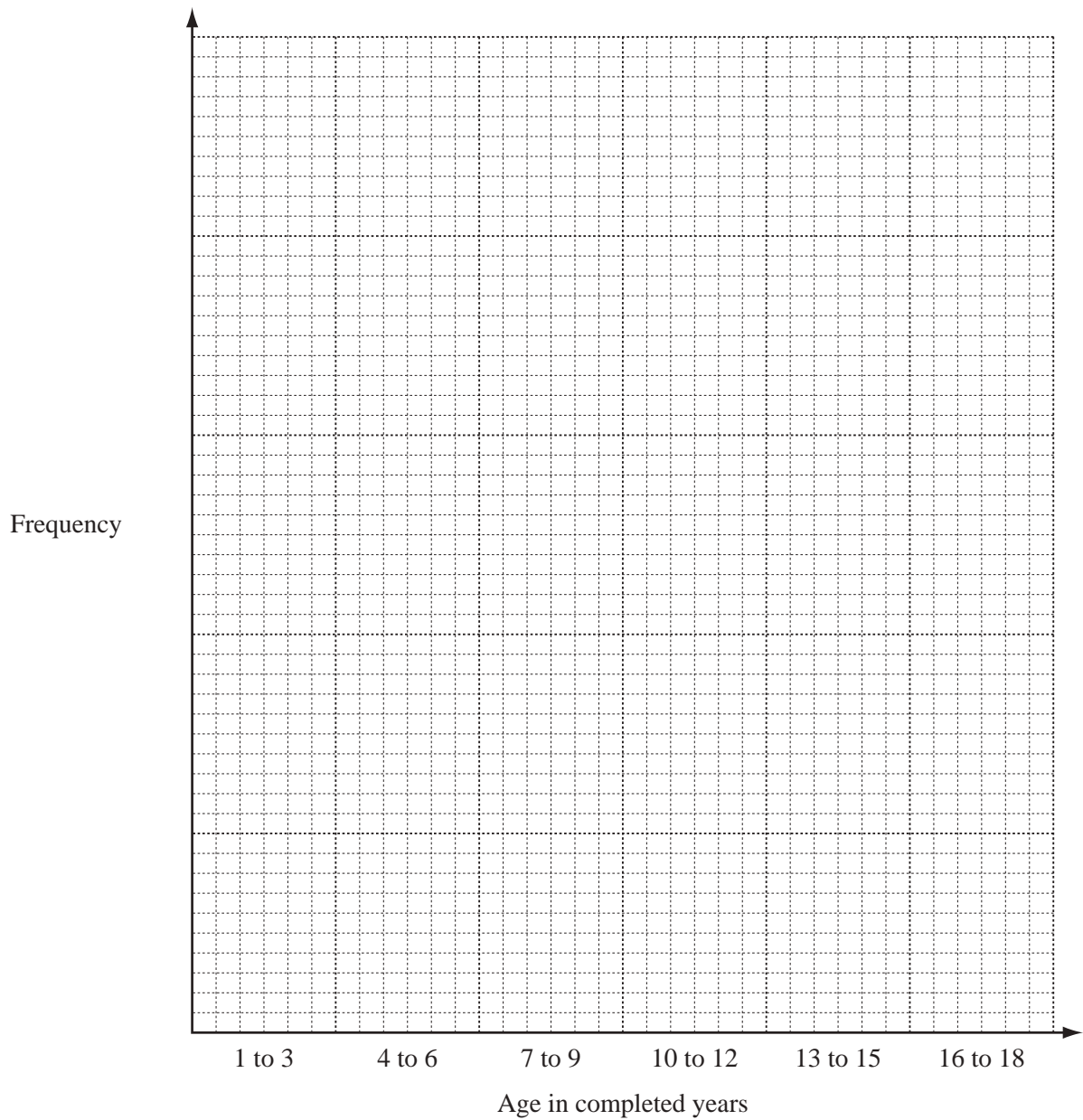

[3]

(ii) What is the modal age group?

Answer(a)(ii) [1]

(iii) One of the 120 children is chosen at random.

Write down the probability that the child is aged 4 to 6.

Answer(a)(iii) [1]

(b) Lalia says the probability of taking a yellow bead from a bag containing yellow beads and black beads is $\frac{7}{5}$.

Explain why $\frac{7}{5}$ cannot be a correct probability.

Answer(b) [1]

(c) Another bag contains 9 green marbles and 11 red marbles.
A marble is taken at random.

Write down the probability that the marble is

(i) green,

Answer(c)(i) [1]

(ii) blue.

Answer(c)(ii) [1]

Question 9 is printed on the next page.

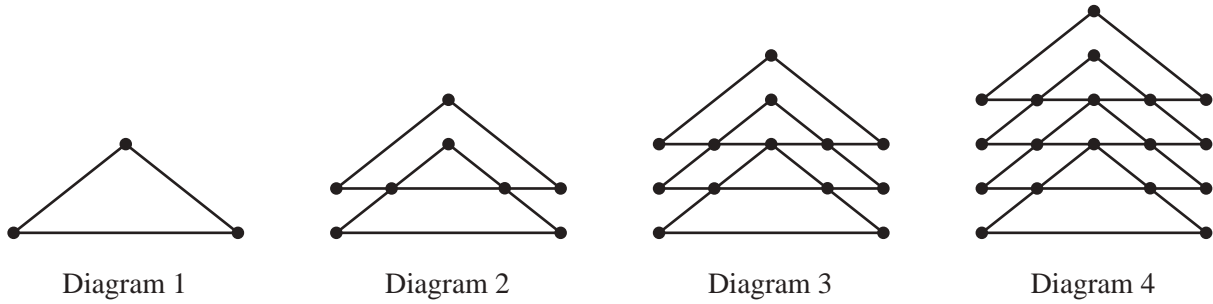

Diagrams 1 to 4 show a sequence of shapes made up of lines and dots at the intersections of lines.

(a) (i) Complete the table showing the number of dots in each diagram.

Diagram	1	2	3	4	5	6
Dots	3	8	13			

[3]

(ii) Write down the rule for continuing the sequence of dots.

Answer(a)(ii) [1]

(iii) Write down an expression, in terms of n , for the number of dots in Diagram n .

Answer(a)(iii) [2]

(iv) Find the number of dots in Diagram 15.

Answer(a)(iv) [1]

(b) The dots are joined by sloping lines and horizontal lines.

(i) Diagram 1 has 2 sloping lines and Diagram 2 has 6 sloping lines.

Find the number of sloping lines in Diagrams 3 and 4.

Answer(b)(i) Diagram 3

Diagram 4 [2]

(ii) Write down an expression, in terms of n , for the number of sloping lines in Diagram n .

Answer(b)(ii) [2]

Permission to reproduce items where third-party owned material protected by copyright is included has been sought and cleared where possible. Every reasonable effort has been made by the publisher (UCLES) to trace copyright holders, but if any items requiring clearance have unwittingly been included the publisher will be pleased to make amends at the earliest possible opportunity.